

# U1281/U1289 U1381/U1387/U1389 Electronic Active Energy Meters

3-349-274-03  
3/11.03

- Acquires active energy
- 2, 3 or 4-wire systems with any load
- Long distance transmission of energy import pulses via S0 interface, pulse rate according to selected features (LON and M bus interfaces in process)
- For household, industrial and commercial applications
- Class 1 or class 2 (PTB approval applied for)
- Direct (U128x) connection or via transformer (U138x)  
– fixed or programmable transformation ratio
- LCD for:
  - Active energy and instantaneous power
  - Phase and phase sequence
  - Reversed current transformer polarity and exceeded ranges
  - Positive or negative active or reactive power
  - Parameters enabling
- CT, VT and S0 parameters can be: fixed, calibrated, adjusted, enabled and disabled
- Test LED for calibration purposes



QUALITY MANAGEMENT SYSTEM



UKAS certified per  
DIN EN ISO 9001:2000  
Reg.No. 1262 QM



## Applications

The electronic active energy meter acquires energy consumption in 2, 3 and 4-wire AC systems.

Its compact rugged design allows for universal use in industrial systems, at construction sites, in office buildings, in leisure facilities and in household applications. The meter can be installed in any position to top-hat rails in accordance with EN 50022.

Installation of the energy meter at incoming supply lines, primary distribution lines or directly at power consumers allows for the recording of energy data and targeted cost allocation. If required, the meter can be calibrated for third party billing.

Energy import pulses are transmitted via the floating pulse output, enabling use together with automated billing systems and for peak load optimization.

Meter readings, measured values and additional information can be read out directly from billing systems, building service control systems and controllers via M bus or LON. Several physically separated meters can be easily linked by means of 2-wire connection, considerably reducing wiring costs as compared with pulse output solutions.

## Applicable Regulations and Standards

<b>DIN EN 61326 VDE 0843, part 20</b>	Electrical equipment for control technology and laboratory use – EMC requirements
<b>IEC/EN 60529 / VDE 0470, part 1</b>	Degrees of protection provided by enclosures (IP code)
<b>DIN 43 856</b>	Electrical power meters, multi-rate tariff switches and ripple-control receivers
<b>DIN 43 864</b>	Electrical interfaces for pulse transmission between impulsing meters and tariff rate devices
<b>IEC 60068-2</b>	Basic environmental testing procedures
<b>IEC 60255-4</b>	High-frequency disturbance test
<b>IEC/EN 61036 / VDE 0418, part 7</b>	Electronic, alternating current, active energy meters (accuracy classes 1 and 2)

## Technical Data

### Multifunctional Design (Feature M1)

In the multifunctional design, 26 additional measured values can be displayed apart from the standard display for active energy and instantaneous power.

Measured quantity	Abbreviation	Accuracy
Phase voltage	U1N, U2N, U3N	0.5% ± 1 d
Delta voltage	U12, U23, U13	0.5% ± 1 d
Current	I1, I2, I3	0.5% ± 1 d
Active power	P1, P2, P3, Ptot	1% ± 1 d
Reactive power	Q1, Q2, Q3, Qtot	1% ± 1 d
Apparent power	S1, S2, S3, Stot	1% ± 1 d
Power factor	PF1, PF2, PF3, PFtot	1% ± 1 d
Frequency	F	0.05% ± 1 d

# U1281/U1289

# U1381/U1387/U1389

## Electronic Active Energy Meters

### Measuring Ranges

Voltage	
See order information	100 V ... 500 V
Allowable deviation	+ 15% / - 20%

Current	
Directly measured $I_B$	5 A
Starting current	Class 1: 0.4% $I_B$ , class 2: 0.5% $I_B$
Directly measured $I_{max}$	65 A
Current transformer $I_B$	1 or 5 A
Starting current	Class 1: 0.2% $I_B$ , class 2: 0.3% $I_B$
Current transformer $I_{max}$	6 A

Frequency range	
Nominal frequency	50 Hz / 60 Hz
Cutoff frequency	45 Hz ... 65 Hz

Accuracy class (feature G)	
Standard	1 or 2 per DIN EN 61036

Sampling rate            continuous 32/period

### LCD

Type                        7-segment characters,  
7-digit main display, height: 6 mm  
8-digit auxiliary display, height: 5 mm

Display range            0 ... 9999999 digits

Refresh                    approx. 6 per second

### Pulse Output

The energy meters are furnished with a pulse output as standard equipment (see below). The pulse output is electrically isolated from the measuring circuit by means of an optocoupler.

### Electrical Values

Pulse generator constants with direct connection	1000 pulses per kWh
Pulse generator constants with transformer connection	1000 pulses per kWh
Pulse duration	30 ms +5%
Interpulse period	>30 ms
$U_{ext}$	max. 40 V (375 V for feature V3, V4)
Switching current	max. 27 mA (100 mA for feature V3, V4)

### Pulse Output

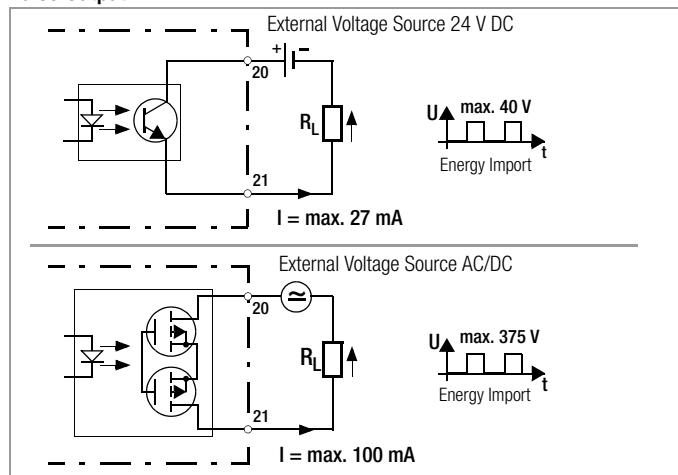

### Power Supply, Auxiliary Power Supply

Internal supply	from measuring voltage: 80 up to 115 % $U_r$
External supply (Feature H1)	Auxiliary voltage: 24 V $\pm$ 10% Current consumption: < 1 W

### Power Failure Backup

Meter parameters and meter readings are retained by an EEPROM in the event of power failure.

If an external auxiliary power supply is utilized (feature H1), meter readings and parameters can also be queried during power failures.

### Power Consumption

Voltage path	
4-wire meter	< 1 VA per phase (including supply power)
2 or 3-wire meter	< 2 VA

Current path	
At $I_{max}$	< 1 VA (direct) < 0.03 VA (transformer)
At $I_B = 1$ A	< 0.001 VA
At $I_B = 5$ A	< 0.02 VA

### Electrical Isolation

Nominal insulation voltage	
Inputs	300 V AC
Output	Feature V1, V2: DC 50 V ( $S\emptyset$ and bus) Feature V3, V4: AC 230 V (pulse)

Insulation test voltage	
Input $\leftrightarrow$ output / housing	4 kV AC
Output $\leftrightarrow$ housing	Feature V1, V2: 500 V ( $S\emptyset$ und bus) Feature V3, V4: 4 kV (pulse)

### Overload Capacity

All meters	Unlimited at 1.15 $U_r$ and $I_{max}$
Direct connection	5 times 3 sec.: $U_r$ and 100 A (interval: 5 min.)
Direct connection	1 times 1 sec.: $U_r$ and 250 A
Transformer connection	0.5 sec.: 20 times $I_{max}$ ; continuous: 10 times $I_{max}$ .

### Electrical Safety

Safety class	II
Overvoltage category	III per DIN EN 61036
Allowable fouling factor	2

### EMC

Electromagnetic Compatibility per DIN EN 61036	
Surge voltage	6 kV, 1.2 / 50 ms 10+ / 10- surges (IEC 60255-4)
Electrostatic discharge	15 kV (DIN EN 61000-2-4)
Electromagnetic fields	10 V / m (DIN EN 61000-4-3)
Burst	2 kV (DIN EN 61000-4-4)
Conducted interference	10 V (DIN EN 61000-4-6)
Interference emission	EN 55022

# U1281/U1289 U1381/U1387/U1389

## Electronic Active Energy Meters

### Ambient Conditions

Nominal operating temperature	-10 ... +45° C
Max. operating temperature	-20 ... +55° C
Storage temperature	-25 ... +70° C
Relative Humidity	< 75% annual average
Elevation	to 2000 m

### Mechanical Data

Housing	
Material	Lexan polycarbonate per UL94 V0
Dimensions	Height ≤ 90 mm
	Overall depth ≤ 75 mm
	Width 125.5 <sup>+0.5</sup> mm
Weight	< 0.5 kg
Installation	Top-hat rail per DIN EN 50022 or wall mounting
Protection	IP 51 (dust protection, vertically dripping water)

### Terminals

Current input	≤ 16 square mm without wire end ferrule
Voltage input	≤ 2.5 square mm with wire end ferrule
	≤ 2 x 1.5 square mm without wire end ferrule
SO pulse input / LON	≤ 2.5 square mm with wire end ferrule ≤ 2 x 1.5 square mm without wire end ferrule
Protection	IP 20

### Dimensional Drawing / Installation

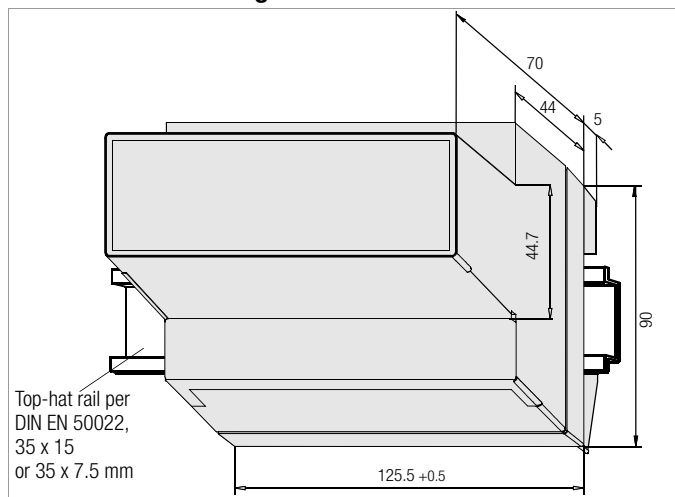

### Symbols and Their Meanings

Symbol	Meaning
CT	Current transformer transformation ratio
CT × VT	Product of CT and VT
f	Frequency
I	RMS current value
I <sub>B</sub>	Nominal current (basic current)
I <sub>max</sub>	Limit current (max. current)
U	RMS voltage value
U <sub>r</sub>	Rated value, input voltage
VT	Voltage transformer transformation ratio

### Terminal Assignments

Self-locking screw terminals are utilized, and are protected with a tamper-proof terminal cover as a standard feature.

### Terminal Circuit Diagrams

2-wire AC system, any load

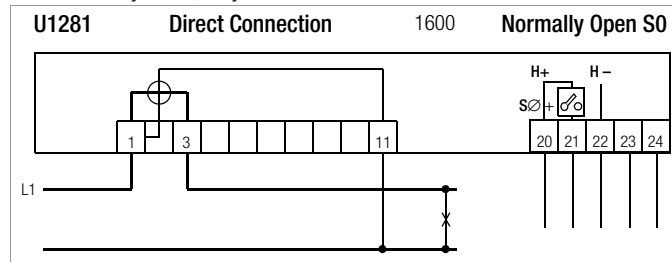

4-wire AC system, any load

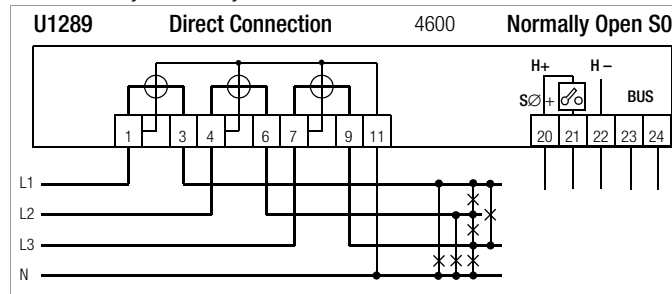

2-wire AC system, any load

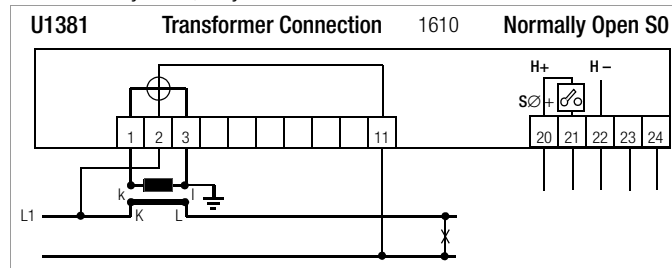

3-wire AC system, any load

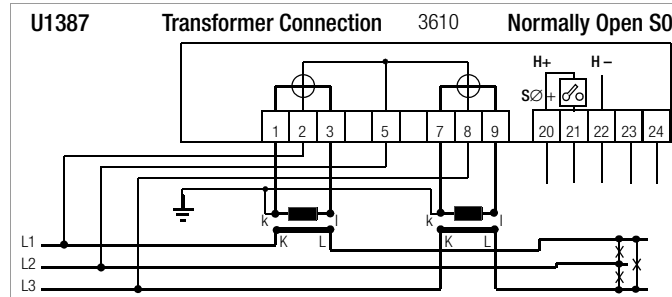

4-wire AC system, any load

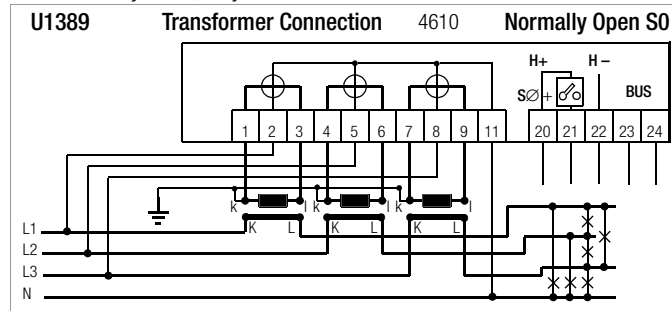

# U1281/U1289

# U1381/U1387/U1389

## Electronic Active Energy Meters

### Order Information

#### Active Energy Meter for Direct Connection

Designation		Article Number / Feature	
Active energy meter for 2-wire, 230 V system	Direct	<b>U1281</b>	
Active energy meter for 4-wire system with any load	Direct		<b>U1289</b>
Line frequency	50 Hz	F0	F0
	60 Hz	F1	F1
Accuracy class	2	G0	G0
	1	G1	G1
24 V DC auxiliary power	Without	H0	H0
	With	H1	H1
Multifunctional design	Without	M0	M0
	With	M1	M1
German approval	w/o calibr.	P0	P0
	With calibr.	P1	P1
P1 plus	calibr. cert.	P2	P2
	230 V	U5	
	400 V		U6
Pulse output	Without	V0	V0
Can be calibrated	1000 pulses per kWh	SØ standard	V1
Programmable rate		SØ progr.	V2
Switching output to 230 V, can be calibrated	1000 pulses per kWh (not possible with H1)	230 V, pulse, standard	V3
Switching output to 230 V	Programmable rate (not possible with H1)	230 V, pulse, programmable	V4
Bus connection	Without	W0	W0
	LON	W1	W1
	M bus	W2	W2
Load profile	Without	Z0	Z0
	(not possible with W0) With	Z1	Z1

SØ values shown on the serial plate can be / are calibrated.

#### Sample order:

4-wire system, any load, accuracy class 2, without external auxiliary power, with German approval and calibration, without calibration certificate, programmable transformation ratio, input voltage: 400 V, with standard SØ pulse output, no bus connection, no load profile

Designation: 1389 D0 G0 H0 P1 Q1 U6 V1 W0 Z0

<sup>1)</sup> Values deviate for U138x and Q9 (with reference to the primary side):

Pulse Rate Table	For V1 and V3, can be calibrated	For V2 and V4, cannot be calibrated
CT x VT	Fixed	Programmable
1 ... 10	1000 pulses per kWh	1 ... 1000 pulses per kWh
11 ... 100	100 pulses per kWh	0.1 ... 100 pulses per kWh
101 ... 1000	10 pulses per kWh	0.01 ... 10 pulses per kWh
1001 ... 10000	1 pulse per kWh	1 ... 1000 pulses per MWh
10001 ... 100000	0.1 pulses per kWh	0.1 ... 100 pulses per MWh
100001 ... 1000000	0.01 pulses per kWh	0.01 ... 10 pulses per MWh

#### Active Energy Meter with Transformer Connection

Designation		Article Number / Feature		
Active energy meter, 2-wire 230 V system	Transformer	<b>U1381</b>		
Active energy meter, 3-wire system, any load	Transformer		<b>U1387</b>	
Active energy meter, 4-wire system, any load	Transformer			<b>U1389</b>
Line frequency	50 Hz	F0	F0	F0
	60 Hz	F1	F1	F1
Accuracy class	2	G0	G0	G0
	1	G1	G1	G1
24 V DC auxiliary power	Without	H0	H0	H0
	With	H1	H1	H1
Multifunctional design	Without	M0	M0	M0
	With	M1	M1	M1
German approval	w/o calibr.	P0	P0	P0
	With calibr.	P1	P1	P1
P1 plus	calibr. cert.	P2	P2	P2
	Fixed transformer ratios: CT = VT = 1 main display can be calibrated	CT = VT=1	Q0	Q0
Programmable transformer ratios: auxiliary display can be calibrated	Programmable CT and VT	Q1	Q1	Q1
Permanently set transformer ratios: CT = 1 ... 10000 VT = 1 ... 1000 CT x VT ≤ 1 million, main display can be calibrated	CT, VT fixed	Q9	Q9	Q9
Rated value, input voltage Ur	100 to 110 V		U3	U3
	230 V	U5		
	400 V		U6	U6
	500 V		U7	
Pulse Output	Without	V0	V0	V0
Can be calibrated 1000 pulses per kWh <sup>1)</sup>	SØ standard	V1	V1	V1
Rate: 1 ... 10000 pulses per kWh, secondary <sup>1)</sup>	SØ programm.	V2	V2	V2
Switching output to 230 V, can be calibrated 1000 pulses per kWh <sup>1)</sup> (not H1)	230 V, pulse, standard	V3	V3	V3
Switching output to 230 V 1 ... 10000 pulses per kWh sec. <sup>1)</sup> (not H1)	230 V, pulse, programmable	V4	V4	V4
Bus connection	Without	W0	W0	W0
	LON	W1	W1	W1
	M bus	W2	W2	W2
Load profile	Without	Z0	Z0	Z0
	(not possible with W0) With	Z1	Z1	Z1

CT, VT and SØ values shown on the serial plate can be / are calibrated.

#### Accessories

Designation	Article Number
Door mount kit (including dimensional drawing)	<b>U270A</b>

Edited in Germany • Subject to change without notice • A pdf version is available on the internet